



**AN INTRODUCTION**

**TO**

**CORROSION MONITORING**

MASTER DOCUMENT NO.0147  
ISSUE E JUNE 05

• • ● **PROTAN S.A.** ● • •

**PROTECCION ANTICORROSIVA**

Wilde 630 Bis. S2007JFT Rosario. Santa Fe. Argentina

Tel.Fax (54 341) 451 3036 / 7128 / 1677

*protan@protansa.com - www.protansa.com*



Cormon: Introduction to Corrosion Monitoring Doc reference CM0147

## **CONTENTS**

### **FOREWORD**

- 1. PHILOSOPHY OF CORROSION MONITORING**
- 2. PRINCIPLES OF CORROSION**
- 3. CORROSION MONITORING TECHNIQUES**
- 4. CEION and ELECTRICAL RESISTANCE (ER) MONITORING**
- 5. CORMON LINEAR POLARISATION RESISTANCE (LPR) MONITORING**
- 6. CORMON RING PAIR CORROSION MONITOR - RPCM**
- 7. CORROSION PROBE FITTINGS STYLES**

• • ● **PROTAN S.A.** ● • •

**PROTECCION ANTICORROSIVA**

Wilde 630 Bis. S2007JFT Rosario. Santa Fe. Argentina

Tel.Fax (54 341) 451 3036 / 7128 / 1677

*protan@protansa.com - www.protansa.com*



Cormon: Introduction to Corrosion Monitoring Doc reference CM0147

## **FOREWORD**

CORMON LTD is a wholly UK owned company which specialises in the design, manufacture and supply of instrumentation and equipment related to corrosion monitoring of pipelines and plant.

The Company provides a comprehensive range of equipment from access fittings to microprocessor controlled on-line systems which facilitate corrosion monitoring by the most common and accepted techniques. In addition, it is our policy to bring to the market newer and improved techniques and instrumentation.

Cormon places emphasis on product quality and reliability. The Company is a BSI Registered Firm for BS EN ISO 9001. Cormon also holds approval for self certification under Module H for the Pressure Equipment Directive

The Company also offers the services of consultancy, design, custom manufacture, installation, commissioning and servicing.

Cormon has set itself to be the first choice supplier of corrosion monitoring solutions by continuing to provide the best quality, reliability, service and delivery. We aim to enhance safety standards in industry and make a positive contribution to the environment by continuously developing our products.

For further details, please contact:

**PROTAN SA**  
**Exclusive Representative**  
**Wilde St # 630 Bis**  
**Zip: S2007JFT**  
**Rosario city**  
**Santa Fe State**  
**Republica Argentina**  
**Phone: 54 – 341 – 4513036**  
**Fax: 54 – 341 – 4517128**  
[protan@protansa.com](mailto:protan@protansa.com)  
[angel@protansa.com](mailto:angel@protansa.com)  
[www.protansa.com](http://www.protansa.com)  
**Contact: Eng. Angel Baldessari**



Cormon: Introduction to Corrosion Monitoring Doc reference CM0147

## **1. PHILOSOPHY OF CORROSION MONITORING**

Corrosion is a degradation mechanism of particular concern in a wide range of industrial plant and plant components. It is an insidious process, often difficult to recognise until deterioration is well advanced. When left unchecked, corrosion will destroy equipment, contaminate products and shut down production.

The report of the 1972 Committee on Corrosion and Protection (The Hoar Committee) estimated that the annual cost of corrosion in the UK was approximately 3% of the Gross National Product, and that savings of almost one third of this were possible by better or wider use of existing techniques such as corrosion monitoring.

Corrosion monitoring is the practice carried out to assess and predict the corrosion behaviour in operational plant and equipment. Some of the objectives of corrosion monitoring are:

- (a) To provide information on the state of operational equipment with the intention of avoiding unplanned shut-downs, occurring due to unforeseen deterioration of the plant.
- (b) To provide information on the interrelation between corrosion processes and operating variables to allow more efficient use of the plant.
- (c) To provide information that plant inspection departments may use to prevent safety failures and potential disasters.
- (d) To assess levels of contamination of process fluids.

In addition, there are more concealed costs associated with corrosion which cover the spectrum from that associated with over design of systems to allow for corrosion through to economic and ecological consequences of plant failure.

In short, corrosion monitoring and technology provides a cost-effective method for assessing the condition of plant, and provides a mechanism whereby life-cycle costs may be minimised.



Cormon: Introduction to Corrosion Monitoring Doc reference CM0147

## 2. PRINCIPLES OF CORROSION

### 2.1 HALF CELL REACTIONS

Corrosion is an electrochemical process in which metals and alloys undergo transformation into predominantly oxides, hydroxides, and aqueous salts.

In the corrosion process, two reactions take place. In one, the anodic reaction, metal atoms are ionised and pass into solution leaving their electrons within the original metal surface. In the second, the cathodic reaction, the free electrons within the metal are taken up by chemical species such as O<sub>2</sub> and H<sub>2</sub>O in reduction reactions.

Consider a simplified version of the corrosion reaction between iron and water. The overall reaction proceeds as follows:

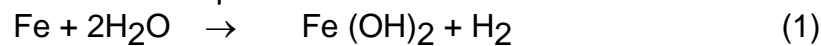

The overall reaction can be broken down into the oxidising ANODIC reaction

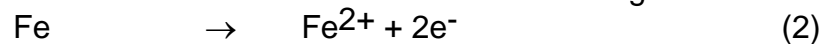

and the reducing CATHODIC reaction

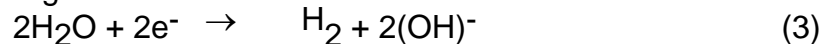

Figure 2.1 depicts this corrosion process.

The reaction 2 and 3 are called 'half cell' reactions. Reaction 2 is the half of the process which is responsible for the damage during corrosion. The speed at which this reaction proceeds is directly related to the corrosion rate.

### 2.2 ELECTRODE POTENTIALS

Values of ELECTRODE POTENTIAL are associated with each of the half cell reactions and give a measure of the likelihood for the reaction to occur. Figure 2.2 depicts standard electrode potentials as measured on the Standard Hydrogen Electrode Scale for some selected half cell reactions. This scale sets as datum a value of zero volts for the reduction of Hydrogen.

The more reactive the metal the more negative is its standard potential. In the case of Iron, it is -0.440V, whereas, for the more inert engineering metals, such as Platinum, the standard electrode potential is +1.20V.

This information allows us to determine whether a metal will corrode in a given environment.

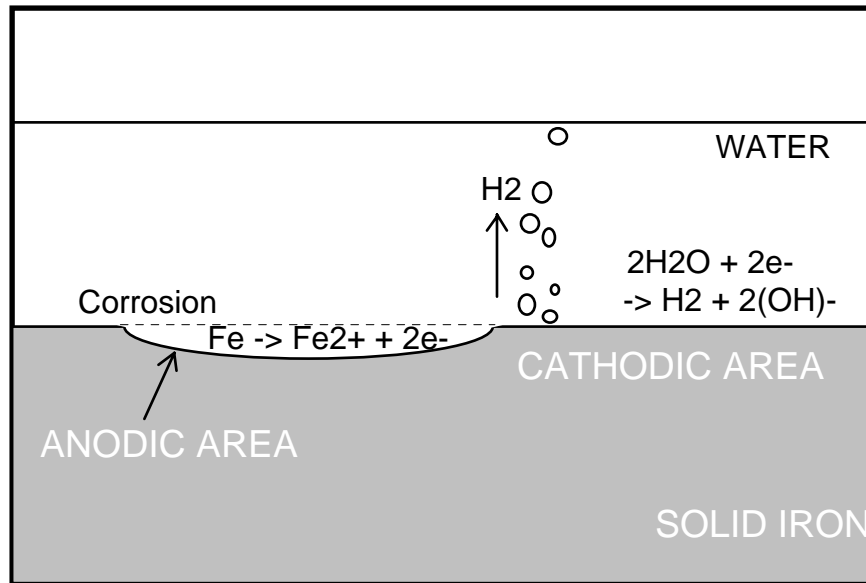

**FIGURE 2.1** - **Schematic of the Corrosion Process**

Half Cell Reactions	Standard Electrode Potential (Volts)
$Zn \rightarrow Zn^{2+} + 2e^-$	-0.76
$Fe \rightarrow Fe^{2+} + 2e^-$	-0.44
$2H^+ + 2e^- \rightarrow H_2$	0.00
$2H_2O + 2e^- \rightarrow H_2 + 2(OH)^-$	0.40
$O_2 + 4H^+ + 4e^- \rightarrow 2H_2O$	1.23
$Cl_2 + 2e^- \rightarrow 2Cl^-$	1.36

**FIGURE 2.2** - **Selected Standard Half-Cell Potentials**

Under standard conditions, the potential of the corrosion cell is the difference between the cathodic reaction half cell potential and the anodic half cell potential. For reaction 1 the potential difference between the cathodic and anodic half cell reactions is:

$$E = +0.401 - (-0.440) = +0.841V$$

The positive value of the potential indicates that the reaction is possible and that corrosion will occur under these conditions. However, theory does not permit the calculation of the corrosion rate; this has to be measured, preferably in-situ. Thus a calculation of the corrosion cell potential is not able to predict the magnitude of damage likely to occur by the corrosion reaction.

### 2.3 CORROSION RATES AND POLARISATION

The existence of a potential difference between the anodic and cathodic half cell regions generates a current flow. This has the effect of reducing the potential difference between the half cells, phenomena known as polarisation. The shape of the polarisation curve is affected by many factors, but in its simplest form is depicted in Figure 2.3.

At the point of intersection of the two polarisation curves, a metal will be freely corroding. The potential at which this occurs is called the Free Corrosion Potential ( $E_{corr}$ ) which generates a Corrosion Current ( $i_{corr}$ ). From the corrosion current, it is possible to calculate corrosion rates.

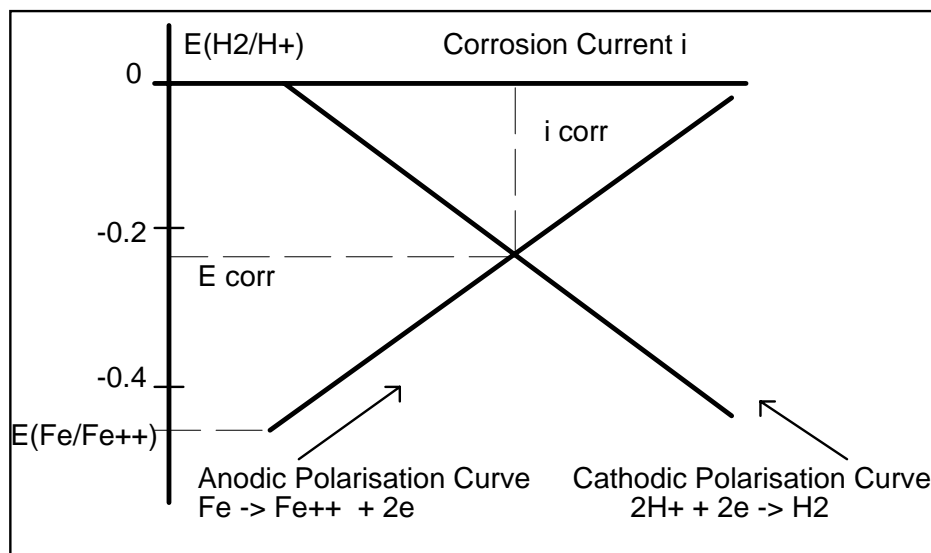

**FIGURE 2.3 - Simple Polarisation Diagram**



Comron: Introduction to Corrosion Monitoring Doc reference CM0147

### **3. CORROSION MONITORING TECHNIQUES**

There exist a number of techniques which may be used to monitor the effects of occurrence of corrosion. These techniques basically fall into seven categories

1. CEION
2. Electrical Resistance Monitoring
2. Electrochemical Methods
3. Hydrogen Monitoring
4. Weight Loss Coupons
5. Non-Destructive Testing (NDT) Techniques
6. Analytical Techniques

#### **3.1 CEION**

CEION is a new ratiometric metal loss measurement device with resolution that is at least 100 times better than existing ER based devices. It is ideal for monitoring oil/gas production and processing systems. A technology that is just as capable of driving the real-time control loop of an inhibitor pump as it is of operating without maintenance between planned shut downs. CEION™ is also first choice technology for sub-sea, sub-surface applications where access and reliability are key factors but fast response is still essential. CEION is also ideally suited to measuring sand erosion in producing systems and a specific set of sensor designs has been developed for this application.

#### **3.2 ELECTRICAL RESISTANCE (ER) MONITORING**

The ER method of corrosion monitoring is one of the most widely used techniques and consists of determining the change in resistance of a metal element as it corrodes in a process environment. The action of corrosion on the element serves to decrease the cross sectional area thereby increasing the electrical resistance. The element is usually in the form of a wire, strip or tube, and if the corrosion is roughly uniform, a change in resistance is proportional to an increment of corrosion. Estimates of the total corrosion over a period may be obtained from successive readings. A simple formula converts to an average corrosion rate.

Electrical resistance probes are rugged and well adapted to any corrosive environment. The ER technique is well proven in practice and is simple to use and interpret. ER monitoring permits periodic or continuous monitoring to be established for one or a multiple number of probes. Corrosion can thus be related to process variables, and the method is one of the primary on-line monitoring tools. The major advantage is its ability to measure corrosion in any environment, liquid, gas or particle streams.

• • • **PROTAN S.A.** • • •

**PROTECCION ANTICORROSIVA**

Wilde 630 Bis. S2007JFT Rosario. Santa Fe. Argentina

Tel.Fax (54 341) 451 3036 / 7128 / 1677

[protan@protansa.com](mailto:protan@protansa.com) - [www.protansa.com](http://www.protansa.com)



Common: Introduction to Corrosion Monitoring Doc reference CM0147

### **3.3 ELECTROCHEMICAL METHODS**

Since corrosion is an electrochemical process, it is not surprising that there exist a number of electrochemical methods for corrosion monitoring. The two electrochemical techniques which are most widely used are Linear Polarisation Resistance Monitoring and Galvanic Monitoring, also known as Zero Resistance Ammetry.

The essential difference between ER and Electrochemical techniques is that ER measurements provide information on total loss of material, whereas electrochemical techniques give rate information.

#### **3.3.1 LINEAR POLARISATION RESISTANCE (LPR) MONITORING**

The LPR technique attempts to respond on a microscopic scale the microscopic corrosion cells existing within the plant. LPR measures the corrosion current flowing between anodic and cathodic half cells. Measurements are made by applying a small voltage ( $\approx 10 - 30\text{mV}$ ) to a corroding metal electrode and measuring the resulting current flow. The ratio of voltage to current - the polarisation resistance - is inversely proportional to corrosion rate.

LPR monitoring provides an instantaneous measure of corrosion rate and may, for example be used as a method for optimising corrosion inhibitor injection. The LPR technique is restricted to aqueous solutions and best results are obtained in highly conductive media. To permit more accurate measurements in solution of higher resistivity, systems have been designed which utilise 3 electrode probes.

#### **3.3.2 GALVANIC MONITORING (ZERO RESISTANCE AMMETRY)**

The principle of the Galvanic technique relies on the fact that when two different metals are immersed in an aqueous liquid they assume different electrode potentials. If these metals are connected externally, a current will flow between them. This current is the result of the half cell reactions taking place simultaneously causing the dissolution (corrosion) of the more negative metal in the solution and the reduction of any available species such as oxygen at the surface of the more positive electrode.

If oxygen is excluded from the system, the reduction process is suppressed and the galvanic current falls to a very low level reflecting the reduced rate of corrosion.

Galvanic measurements are particularly applicable to the detection of the ingress of oxygen into systems protected by de-aeration. Also, they provide a rapid, continuous method for assessing corrosive conditions in aqueous flows.

• • • **PROTAN S.A.** • • •

**PROTECCION ANTICORROSIVA**

Wilde 630 Bis. S2007JFT Rosario. Santa Fe. Argentina

Tel.Fax (54 341) 451 3036 / 7128 / 1677

[protan@protansa.com](mailto:protan@protansa.com) - [www.protansa.com](http://www.protansa.com)



Cormon: Introduction to Corrosion Monitoring Doc reference CM0147

### **3.4 HYDROGEN MONITORING**

Hydrogen Monitoring is an important facet of corrosion monitoring, since the detection of hydrogen provides an indication that corrosion is taking, or has taken place.

In particular, in situations where plant is exposed to wet sour gas (H<sub>2</sub>S), or acid conditions, the generation of hydrogen is of primary concern.

Under such conditions hydrogen may be directly absorbed into the fabric of the plant and produce blistering, embrittlement, stress corrosion cracking and other hydrogen induced problems.

Hydrogen monitoring probes exist which can be either inserted into the plant in order to measure the presence of hydrogen, or conversely attached to the exterior of the plant in a saddle mode capable of detecting the diffusion of hydrogen through the plant.

### **3.5 WEIGHT LOSS COUPONS**

Weight loss coupon monitoring is the oldest method for assessing the corrosivity of an environment on a specific material and involves exposing a specimen (coupon) of the material to the environment for a given duration, and measuring the resultant weight loss. The coupons can be in the form of discs, rods, plates or of any convenient shape.

Coupons are not an instrumental method, and require extensive manual involvement in order to provide information. Also, coupons only provide integrated corrosion loss data. However, the advantages of coupons include:

- Visual interpretation
- Deposits can be observed and analysed
- Weight loss can be readily determined
- The degree of localisation of corrosion can be observed and measured.

• • ● **PROTAN S.A.** ● • •

**PROTECCION ANTICORROSIVA**

Wilde 630 Bis. S2007JFT Rosario. Santa Fe. Argentina

Tel.Fax (54 341) 451 3036 / 7128 / 1677

*protan@protansa.com - www.protansa.com*

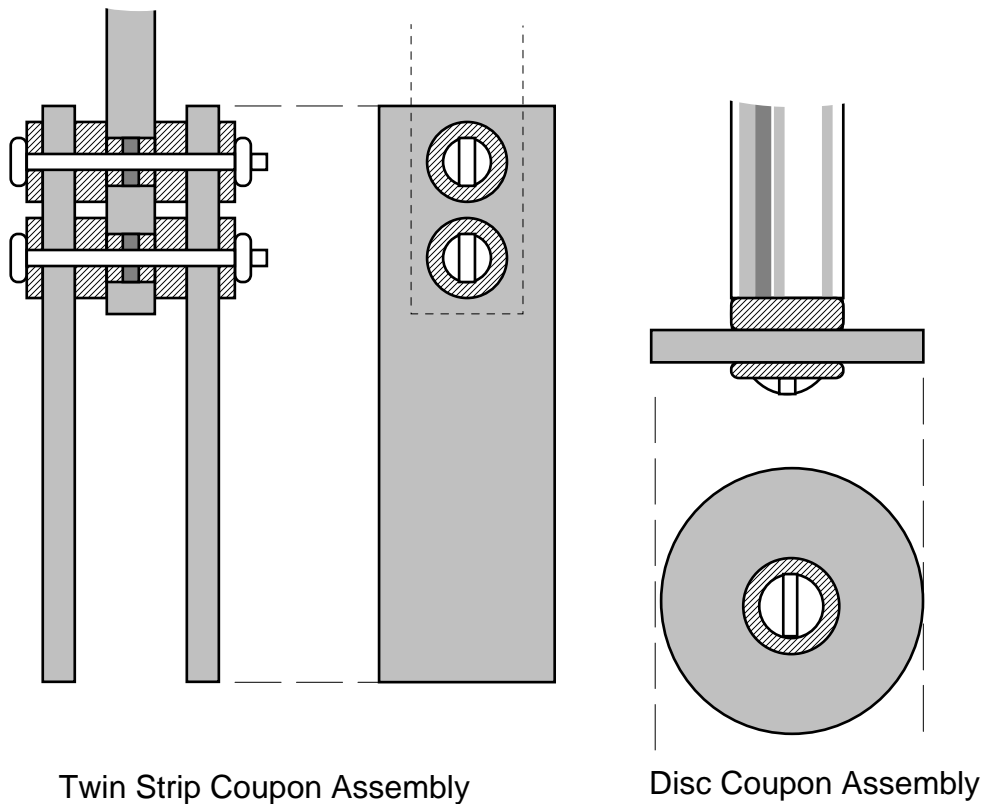

**FIGURE 3.1                      Examples of Weight Loss Coupons**

### **3.6    NON-DESTRUCTIVE TESTING (NDT) TECHNIQUES**

A comprehensive range of NDT techniques exist which complement the 'instrumentation' techniques previously described. These include ultrasonics, radiography, thermography, eddy current measurement and various others. Such techniques usually fall into the area of plant inspection.

### **3.7    ANALYTICAL TECHNIQUES**

A number of analytical techniques are used to look at the process fluid chemistry. This usually involves drawing off fluid samples for laboratory analysis. Areas of interest under this heading are iron counts, chloride counts, oxygen, conductivity and pH measurements, flow measurements and temperature.



Comon: Introduction to Corrosion Monitoring Doc reference CM0147

### **3.8 SUMMARY**

In practical corrosion monitoring programmes it is usual for several corrosion monitoring techniques to be used, with some element of correlation being established.

The preferred methods are Coupon and CEION or ER monitoring, with emphasis on the latter, since CEION & ER monitoring provides useful information on a day by day basis and measurements may be made without the requirement for the probe to be retrieved from the system.

• • ● **PROTAN S.A.** ● • •

**PROTECCION ANTICORROSIVA**

Wilde 630 Bis. S2007JFT Rosario. Santa Fe. Argentina

Tel.Fax (54 341) 451 3036 / 7128 / 1677

*protan@protansa.com - www.protansa.com*



Cormon: Introduction to Corrosion Monitoring Doc reference CM0147

## **4. CEION and ELECTRICAL RESISTANCE (ER) MONITORING**

### **4.1 INTRODUCTION**

The CORMON CEION and ER systems are based on the fundamental concept that the action of corrosion on an exposed metal element will reduce the cross sectional area of the element, thereby increasing its electrical resistance. The value of the resistance increases in a predictable manner with depth of corrosion, thereby permitting the accurate determination of the metal loss occurring.

Measurements are made by comparing the resistance of an exposed sacrificial element to that of a reference element sealed within the body of the probe. In this way, temperature compensated measurements can be made.

Portable and on-line automatic instrumentation is available to permit periodic or continuous monitoring.

### **4.2 THEORY OF OPERATION**

The electrical resistance of an element of metal is given by

$$R = \frac{\rho l}{a}$$

Where

$\rho$  is the material resistivity

$l$  is its length

and

$a$  is its cross sectional area.

Thus for a given length of element, the resistance varies inversely with cross sectional area.

When the thickness of the element is diminished by a uniform corrosion attack, the reduction in thickness will cause a predictable change in the resistance of the element.

### **4.3 CEION TECHNOLOGY**

In the advanced metal loss technology CEION, Cormon has advanced the resolution of the ratiometric. The key features of the instrumentation are:

- The method of excitation
- The measurement of the response.
- High immunity to noise

• • • **PROTAN S.A.** • • •

**PROTECCION ANTICORROSIVA**

Wilde 630 Bis. S2007JFT Rosario. Santa Fe. Argentina

Tel.Fax (54 341) 451 3036 / 7128 / 1677

[protan@protansa.com](mailto:protan@protansa.com) - [www.protansa.com](http://www.protansa.com)



Common: Introduction to Corrosion Monitoring Doc reference CM0147

- Precision analogue circuitry
- Advanced digital signal processing
- Temperature measurement

The high signal to noise ratio allows field detection of 1 – 2 nm loss from 0.5mm thick sensor.

The development of sensors with high repeatability forms part of the scope. As instrument resolution improved so did the ability to evaluate sensor performance. The current generation of CEION sensor designs has excellent repeatability.

In addition to achieving sensor repeatability, it is necessary to have confidence in the corrosion repeatability of the sensor element. Will the element material in two different sensors from the same batch give close corrosion rate results in an identical environment, or will small differences in the material properties lead to divergent results? The evidence from the testing was that a difference in corrosion behaviour from probe to probe was likely if key factors are not recognised and incorporated into the design. In addition, quality control in manufacture is critical.

Typically, using a standard 10 hour exposure test of two probes to a 1% solution of sodium chloride, a metal loss between 10 and 10.5 nm/hr is measured showing that variance in the corrosion susceptibility of sensor element material has been controlled.

As a result of the development and testing it is possible to demonstrate the ability to measure the loss of 1nm of material within 5 minutes.

• • • **PROTAN S.A.** • • •

**PROTECCION ANTICORROSIVA**

Wilde 630 Bis. S2007JFT Rosario. Santa Fe. Argentina

Tel.Fax (54 341) 451 3036 / 7128 / 1677

*protan@protansa.com - www.protansa.com*



**Fig. 4.1 CEION Probe Element**

A number of special applications for CEION have been developed, these include Sand Erosion monitoring and the use of cooled probes to simulate condensation in operating systems.

#### **4.4 ER - PRACTICAL APPROACH**

The CORMON philosophy of ER monitoring is to use the most up-to-date electronic instrumentation to obtain measurements of the absolute resistance of the probe elements.

Whereas in older conventional style instruments a bridge circuit is used to measure the sample and reference element resistances, this new approach measures directly the absolute resistance of the elements, from which the depth of corrosion is calculated. This philosophy permits the user to offset inherent variations in probe build.

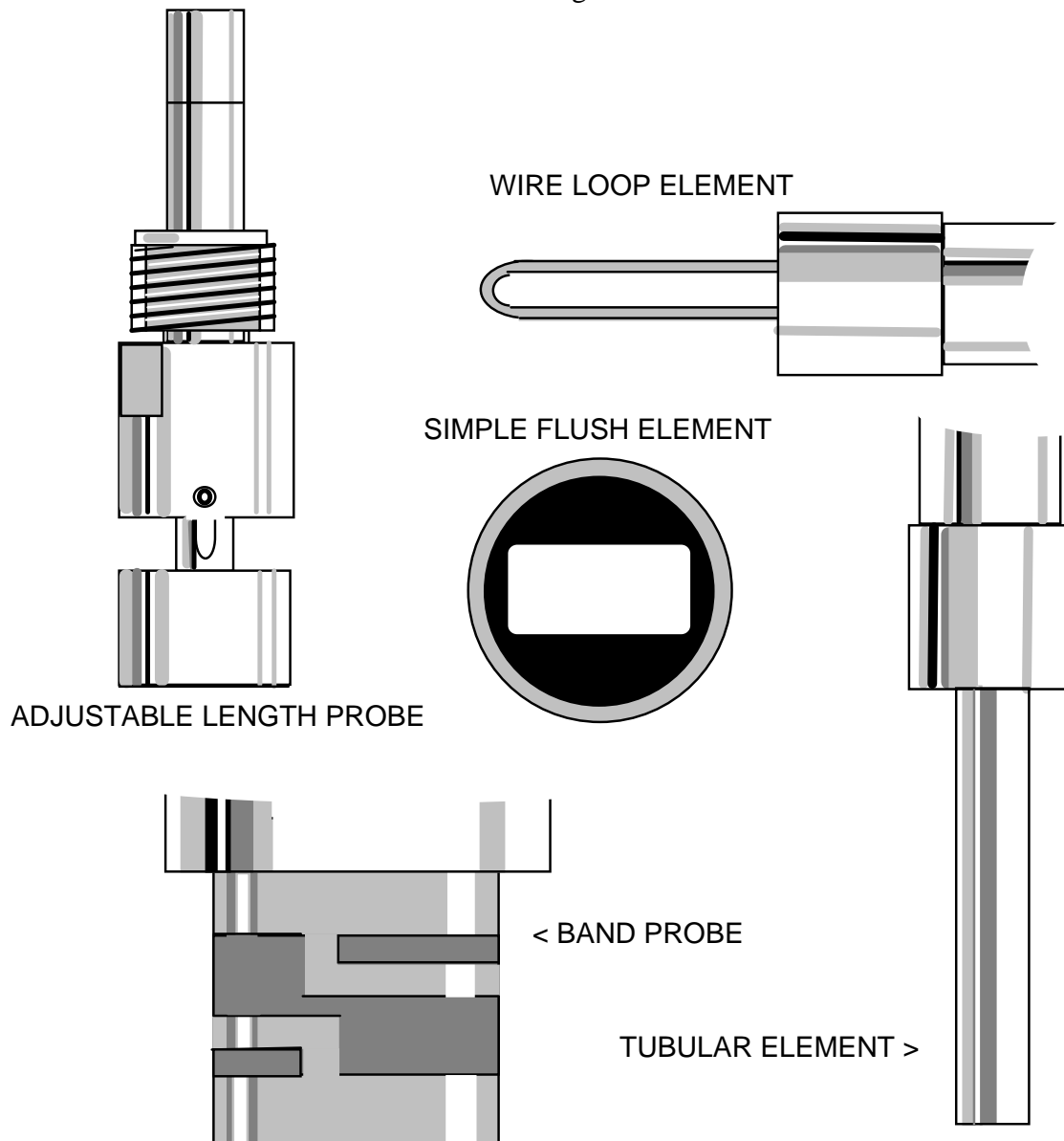

**FIGURE 4.2 Examples of Electrical Resistance Probes**

#### 4.5 CORROSION MEASUREMENTS

The values of the absolute resistance of the Sample ( $R_S$ ) and Reference ( $R_R$ ) elements are measured and the ratio  $R_S / R_R$  determined. A database calibration is used to determine the actual depth of corrosion given  $R_S / R_R$ , and from this, information on rate of corrosion may be calculated if required. The database calibration depicts how the value of  $R_S / R_R$  varies as a function of depth of corrosion. It is important to realise that each thickness and style of probe element has its own database calibration, and that accurate ER

• • • **PROTAN S.A.** • • •

**PROTECCION ANTICORROSIVA**

Wilde 630 Bis. S2007JFT Rosario. Santa Fe. Argentina

Tel.Fax (54 341) 451 3036 / 7128 / 1677

[protan@protansa.com](mailto:protan@protansa.com) - [www.protansa.com](http://www.protansa.com)



Cormon: Introduction to Corrosion Monitoring Doc reference CM0147  
measurements can only be obtained by reference to this characteristic. A typical characteristic is shown in figure 4.1.

## 4.6 PROBES

ER probes are configured in several element geometries, the most common being wire loops, cylindrical tubes and flush mounted strips. Cormon have recently developed a Band probe for service in pitting corrosion situations where scaling and physical damage are possible.

Selection of the most appropriate probe and its location depends on a number of factors. Probes should be located at:

- Positions of special sensitivity where turbulence, velocity mixing, temperature or pH etc. may be of concern.
- Positions where upsets may occur i.e. after inhibitor addition, acid concentration or separation.
- Sites where abrupt changes occur such as plant metallurgy, process fluids, etc.
- Positions where from experience the highest corrosion rates would be expected.

ER probes are available in a variety of materials to suit various metallurgical applications. Probes are designed to accommodate a wide range of pressures and temperatures. Typical of the upper working limits of standard probes 6000psi and 250°C, although custom built designs may be able to extend this operation.

Process probes are available in both fixed and retrievable configurations. (see section 7).

## 4.7 INSTRUMENTATION

ER probes may be monitored manually using portable equipment, automatically/continuously using single, multichannel hardwired instruments, via a computer controlled on-line system or by means of data logging equipment.

### 4.7.1 MANUAL INSTRUMENTS

The CORMON IER 2000 is a battery powered instrument designed to carry out field measurements of ER probes. The instrument lead couples to the in-



Cormon: Introduction to Corrosion Monitoring Doc reference CM0147  
situ probe, and a simple sequence enables quick and easy evaluation of the probe to be made.

This provides the basic technique whereby corrosion information is gathered on a periodic basis.

The IER 2000 Instrument is BASEEFA approved for operation in hazardous environments.

#### **4.7.2. DATA LOGGING INSTRUMENTS**

The Cormon Data Collection Units are free standing remote data logging instruments in either ER or LPR configuration. When installed at a probe site the units make and store measurements at programmed intervals over any period. These robust, simple to use but highly efficient instruments also have an error messaging system to indicate when an acceptable measurement cannot be made - when the probe life has expired for example. The benefits of data logging include:

- Much more information achieved at moderate cost with minimum manpower
- Better quality of information and better understanding of its relation to time and process conditions.
- Ease and flexibility of operation that frees time once spent on data acquisition and handling for problem solving

#### **AUTOMATIC MONITORING**

For details of Cormon's full range of hard-wired single and multichannel instrumentation as well as fully automatic microprocessor controlled systems, the reader is referred to the CORMON product binder.

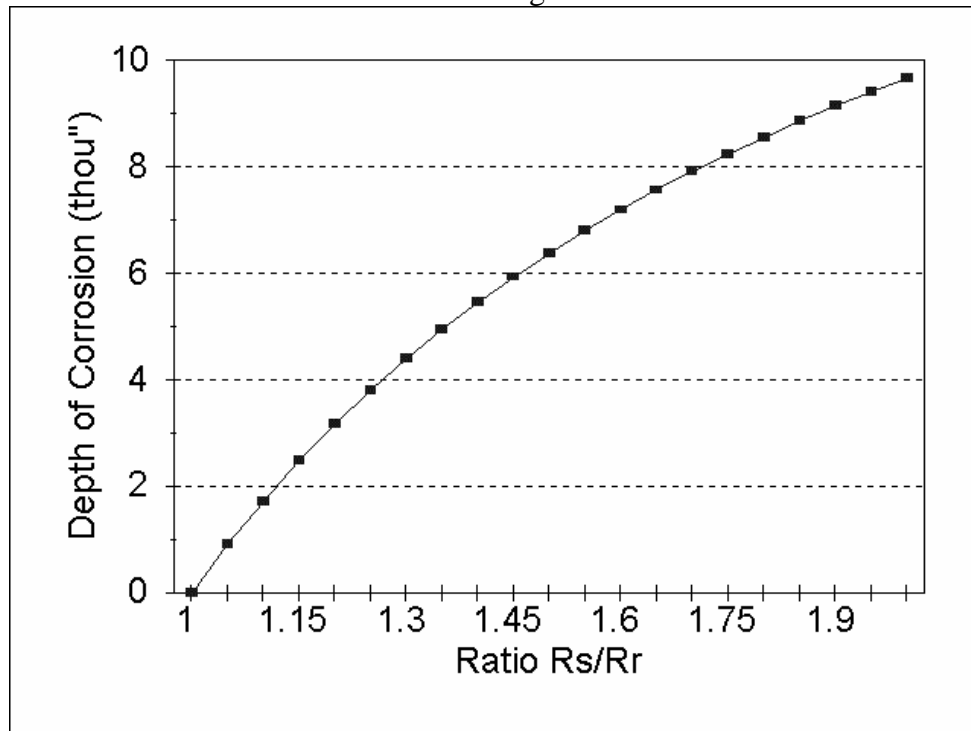

**FIGURE 4.3 Calibration characteristic for a T20 tubular element probe showing the non-linear relationship between element resistance and depth of corrosion.**

## **5. CORMON LINEAR POLARISATION RESISTANCE (LPR) MONITORING**

### **5.1 INTRODUCTION**

The CORMON LPR measurement technique is based on the fundamental concept that when a test electrode in an aqueous environment is polarised by a small voltage, the apparent resistance measured from resulting current flow is inversely proportional to the corrosion rate. The CORMON Monitoring System makes use of conventional 2 and 3 electrode probes.

LPR monitoring is particularly applicable to the following areas:

- Cooling Water Systems
- Chemical Injection/Inhibitor Systems
- Desalination Plants
- Waste Water Systems
- Oilfield Waterfloods
- Chemical Cleaning

• • • **PROTAN S.A.** • • •

**PROTECCION ANTICORROSIVA**

Wilde 630 Bis. S2007JFT Rosario. Santa Fe. Argentina

Tel.Fax (54 341) 451 3036 / 7128 / 1677

[protan@protansa.com](mailto:protan@protansa.com) - [www.protansa.com](http://www.protansa.com)



Comron: Introduction to Corrosion Monitoring Doc reference CM0147

## 5.2 THEORY OF OPERATION

When a metal is immersed in a corrosive medium and allowed to undergo corrosion, it will assume a potential known as the free corrosion potential,  $E_{\text{corr}}$

If an additional voltage is applied to the metal to perturb it from its free corroding potential, a current will flow between the metal and corrodent. If the perturbation voltage ( $\Delta E$ ) is sufficiently small, the magnitude of the current flow ( $\Delta I$ ) will be proportional to the applied perturbation voltage, such that

$$\frac{\Delta E}{\Delta I} = \text{constant} \quad (1)$$

The constant has the dimension of resistance and is known as the 'Polarisation Resistance'  $R_p$ .

$$\frac{\Delta E}{\Delta I} = R_p \quad (2)$$

Thus, the Linear Polarisation Resistance technique derives its name from the fact that a linear relationship exists between the polarisation of a metal in contact with a corrodent and the current induced to flow by the application of the polarisation.

• • ● **PROTAN S.A.** ● • •

**PROTECCION ANTICORROSIVA**

Wilde 630 Bis. S2007JFT Rosario. Santa Fe. Argentina

Tel.Fax (54 341) 451 3036 / 7128 / 1677

[protan@protansa.com](mailto:protan@protansa.com) - [www.protansa.com](http://www.protansa.com)

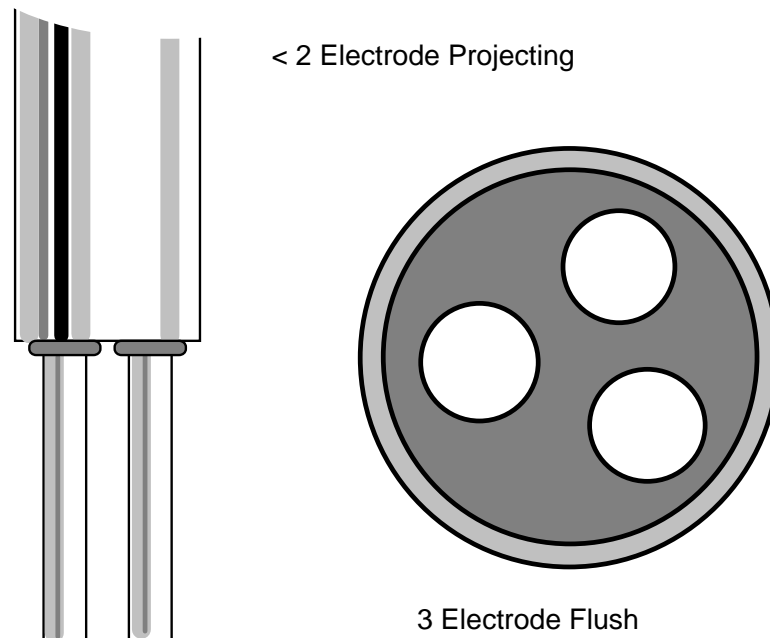

**FIGURE 5.1** Examples of LPR probes

## 6. ***CORMON RING PAIR CORROSION MONITOR - RPCM***

### 6.1 INTRODUCTION

RPCM™ is an in-line, piggable, monitor for pipelines, flow lines and process pipework giving true corrosion rate measurement in all service conditions due to full bore, flow through geometry. The high resolution of the metal loss measurement technology makes RPCM™ an effective tool for flow assurance applications. The scalable, modular approach to the design of the sensor housing allows other measurement techniques to be incorporated and permits the overall device to be customised to suit the particular ‘mission statement’ of the application.

The ‘ring-pair’ design consists of co-axially spaced closed rings, pairing a corrosion-sensing ring with an electrically isolated reference ring. The process flow is unimpeded through the rings. The arrangement provides the optimum





Cormon: Introduction to Corrosion Monitoring Doc reference CM0147  
compensation for temperature and stress while closely simulating the corrosion interface at the internal wall of the pipeline. Precision monitoring of metal loss from thick rings is possible by virtue of the high resolution CEION<sup>®</sup> measurement system. The design permits resolution of metal loss in the sub-micron range, 10 -20 times improvement on other techniques.

RPCM<sup>™</sup> Spools are constructed using the 'double block' principle. An **inner spool**, consisting of the Ring-pairs, spacers and seals in compression, is capable of holding design pressure and is the primary containment. The inner spool is sealed into an equally pressure capable **outer housing**, providing a secondary containment. Electrical connections to the rings pass through high integrity glass sealed penetrators welded into the outer housing. Compliance with design codes for pipelines and pressure vessels ensures that each design can be fully certified, for example, the all welded design has been accredited by DNV for service subsea according to BS8010 Pt 3 and BS4515. The spool can be mated to the pipeline with flanges, hubs or by welding.

## 6.2 BASIC SPECIFICATIONS

Metal loss resolution: sub micron general metal loss detection with pitting detection/discrimination. Temperature measurement  $\pm 2^{\circ}\text{C}$ .

Operating envelope – as pipeline.

Water depth, currently up to 2000m (limited by underwater mateable connector technology thereafter)

## 6.3 APPLICATIONS

While the RPCM<sup>™</sup> concept is applicable to all types of pipeline monitoring, the most fully developed application to date is associated with the management of carbon steel subsea pipelines and flowlines transporting untreated well streams.

## 6.4 INNOVATION AND BENEFITS

The RPCM<sup>™</sup> is innovative in two main areas – the scaleable, modular housing and the corrosion measurement technology.

Housing: The design is easily customised to different pipe diameters and wall thickness and to accommodate the appropriate sensor configuration. The design provides an extremely flexible

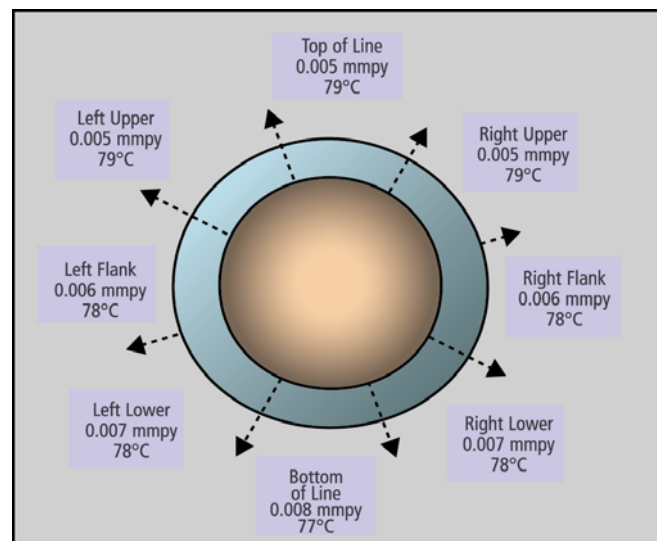

••• **PRO**  
**PROTECCIC**  
Wilde 630 Bis. S2007JF  
Tel.Fax (54 341)  
[protan@protansa](mailto:protan@protansa).



Common: Introduction to Corrosion Monitoring Doc reference CM0147 means of exposing wetted sensors of almost any type to flowing pipeline conditions without changing the flow regime. The double block principle is employed throughout to ensure the integrity of the line.

Corrosion Measurement: The RPCM™ ring concept allows 360° coverage, with discrimination in 8 equal 45° sectors, at a resolution level that moves corrosion management into the real-time domain. Additional features of the ring configuration can be exploited to discriminate between pitting and general corrosion. This type of capability would normally be associated with high maintenance, short life, single point sensors, while RPCM is able to provide intervention free service life to equal the pipeline design life.

Benefits: In many subsea production applications the viability of projects is governed by pipeline cost. The use a carbon steel pipeline is frequently the only commercially viable option despite the increased difficulty in managing the risk of internal corrosion. Viability will depend on effective use of chemical inhibitors to control corrosion and the level of confidence that the operator has in the performance and delivery of the chemical. When problems occur, delay in detection is directly proportional to lost pipeline life. The effective, high resolution monitoring available from RPCM is an 'enabling technology' for such projects, permitting the development of otherwise uneconomic reserves. Where considerations such as slug flow or hydrate formation are cause for concern the suite of sensors can be tuned to provide additional indicators of in-line conditions offering added versatility to the RPCM™ as a flow-assurance tool.

## **7. FITTING SYSTEMS**

There are two basic styles of fitting for corrosion probes, fixed and retrievable under pressure. Where fixed probes are used, the plant or process normally requires a shutdown or depressurization period in order for the probes to be removed from the system. Retrievable/Retractable probes are designed to be installed and removed from locations whilst plant is under operating conditions, and without shutdown.

### **7.1 FIXED FITTINGS**

Probes with fixed fittings are coupled directly into plant usually via a female half coupling welded onto the plant. Typical specifications for fitting are NPT which are capable of working at pressures of up to 1500psi.

• • ● **PROTAN S.A.** ● • •

**PROTECCION ANTICORROSIVA**

Wilde 630 Bis. S2007JFT Rosario. Santa Fe. Argentina

Tel.Fax (54 341) 451 3036 / 7128 / 1677

[protan@protansa.com](mailto:protan@protansa.com) - [www.protansa.com](http://www.protansa.com)



Comon: Introduction to Corrosion Monitoring Doc reference CM0147

Adjustable coupling variations of this style are available to permit probes to be positioned for optimal insertion. Pressure ratings as per standard swage lock fittings are available.

For high pressure fixed applications it is common for flanged probes to be used.

## **7.2 RETRIEVABLE FITTINGS**

There are several operating systems which permit probes to be installed and retrieved during normal plant operation. The two most common are the 2" High Pressure Access System and the 1" Low Pressure Access System (5/8" diameter). These are usually referred to as the Retrievable and Retractable systems respectively.

The 2" High Pressure System enables probe insertion and withdrawal at pressures up to 6000 psi using special probe carriers (2" access fittings) and retrieval tools.

The 1" Low Pressure System is based on a packing gland concept and insertion is accomplished via port valve. The system is limited capable of pressures up to 1500 psi.

## **7.3 SPECIAL APPLICATIONS**

There are many instances where standard fittings are not suitable for mounting probes to meet the monitoring requirement. In these cases customisation is often possible. Comon has an extensive design capability in this area.

• • • **PROTAN S.A.** • • •

**PROTECCION ANTICORROSIVA**

Wilde 630 Bis. S2007JFT Rosario. Santa Fe. Argentina

Tel.Fax (54 341) 451 3036 / 7128 / 1677

*protan@protansa.com - www.protansa.com*